

PS POR B	PS_POR_B
PS ENET0 TX DATA0	PS_ENET0_TX_DATA0
PS ENET0 TX DATA1	PS_ENET0_TX_DATA1
PS ENET0 TX DATA2	PS_ENET0_TX_DATA2
PS ENET0 TX DATA3	PS_ENET0_TX_DATA3
PS ENET0 GTX_CLK	PS_ENET0_GTX_CLK
PS ENET0 TX_EN	PS_ENET0_TX_EN
PS ENET0 RX_DATA0	PS_ENET0_RX_DATA0
PS ENET0 RX_DATA1	PS_ENET0_RX_DATA1
PS ENET0 RX_DATA2	PS_ENET0_RX_DATA2
PS ENET0 RX_DATA3	PS_ENET0_RX_DATA3
PS ENET0 RX_CLK	PS_ENET0_RX_CLK
PS ENET0 RX_DV	PS_ENET0_RX_DV
PS ENET0 MDC	PS_ENET0_MDC
PS ENET0 MDIO	PS_ENET0_MDIO

武汉芯路恒科技有限公司

Title		
AC850-CB		
Size	File	Version
A4	02_PS_ETH	25061601
Date: Monday, September 01, 2024		
Sheet		of
2		16

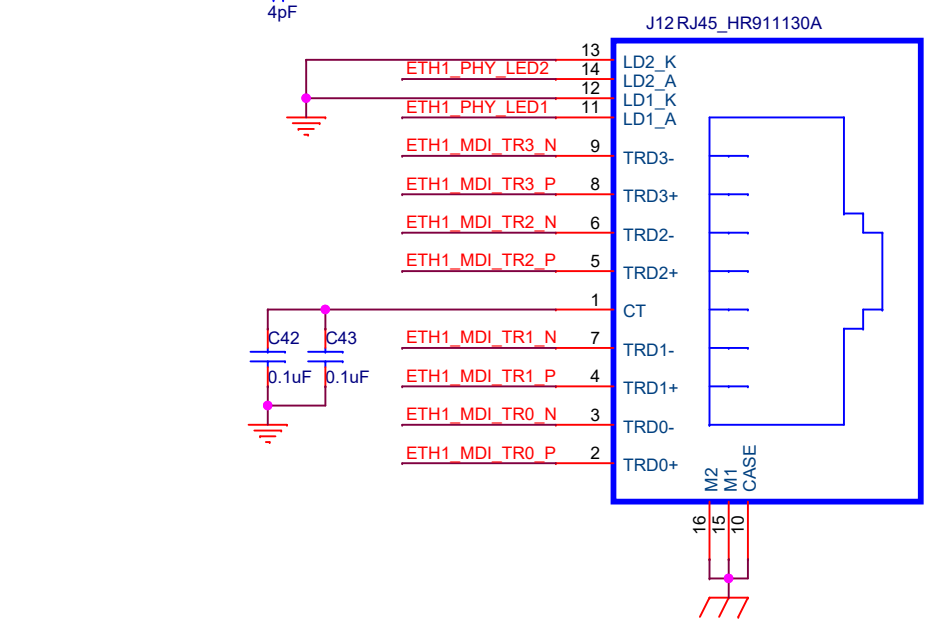
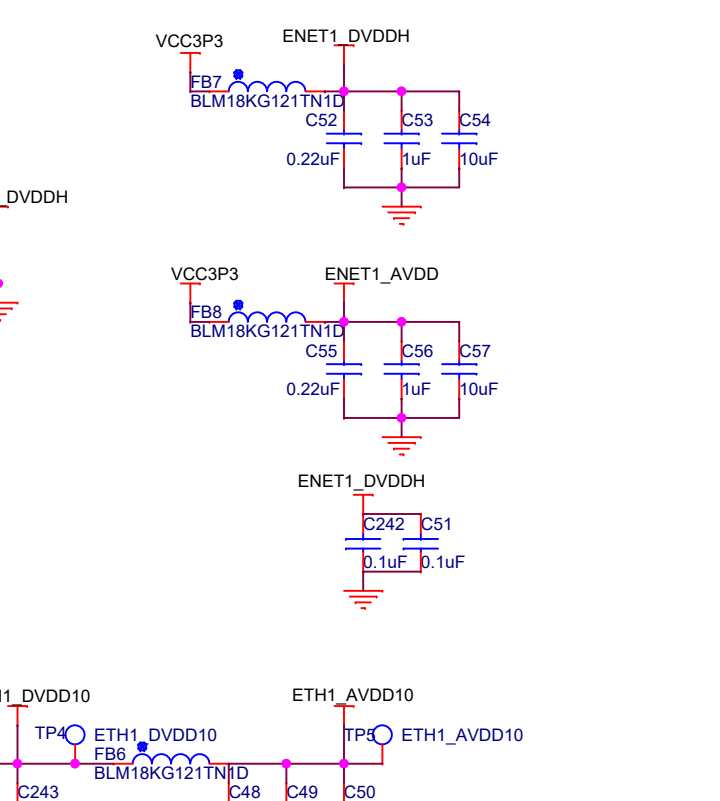
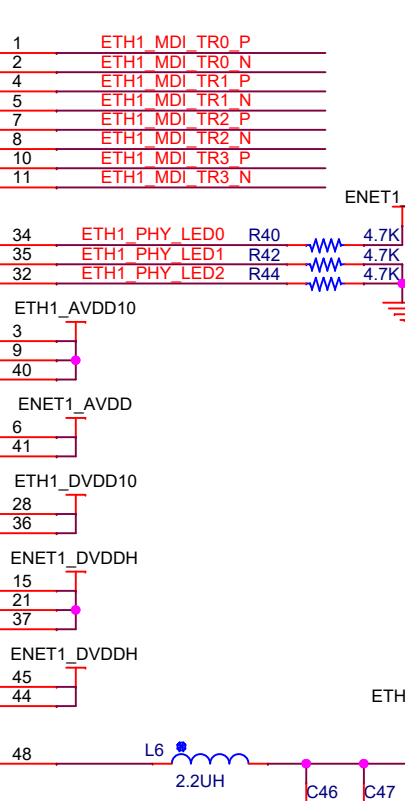
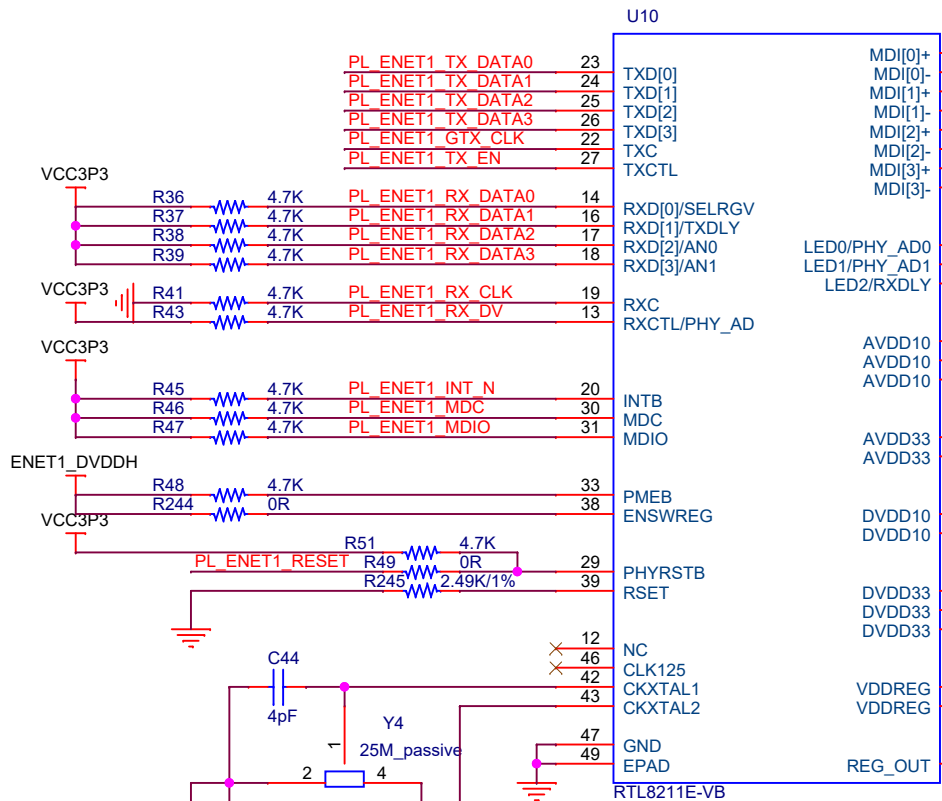

- PL_ENET1_RESET <> PL_ENET1_RESET
- PL_ENET1_TX_DATA0 <> PL_ENET1_TX_DATA0
- PL_ENET1_TX_DATA1 <> PL_ENET1_TX_DATA1
- PL_ENET1_TX_DATA2 <> PL_ENET1_TX_DATA2
- PL_ENET1_TX_DATA3 <> PL_ENET1_TX_DATA3
- PL_ENET1_GTX_CLK <> PL_ENET1_GTX_CLK
- PL_ENET1_TX_EN <> PL_ENET1_TX_EN
- PL_ENET1_RX_DATA0 <> PL_ENET1_RX_DATA0
- PL_ENET1_RX_DATA1 <> PL_ENET1_RX_DATA1
- PL_ENET1_RX_DATA2 <> PL_ENET1_RX_DATA2
- PL_ENET1_RX_DATA3 <> PL_ENET1_RX_DATA3
- PL_ENET1_RX_CLK <> PL_ENET1_RX_CLK
- PL_ENET1_RX_DV <> PL_ENET1_RX_DV
- PL_ENET1_MDC <> PL_ENET1_MDC
- PL_ENET1_MDIO <> PL_ENET1_MDIO

武汉芯路恒科技有限公司		
Title AC850-CB		
Size A4	File 03_PL_ETH	Version 25061601
Date: Monday, September 01, 2024 Sheet 3 of 16		

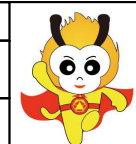

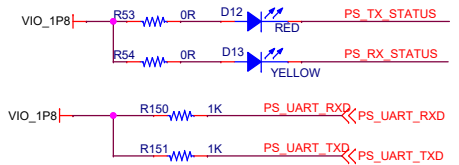
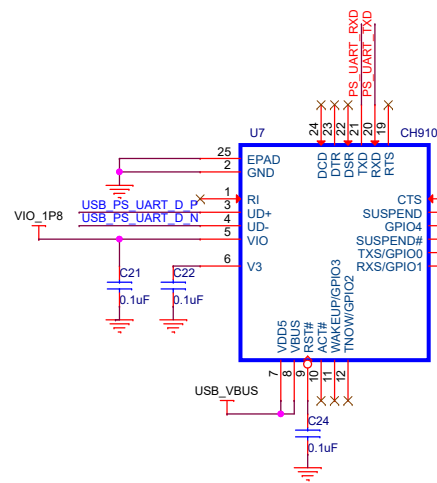
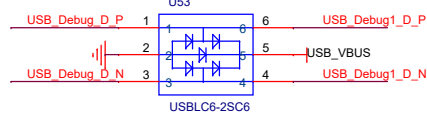
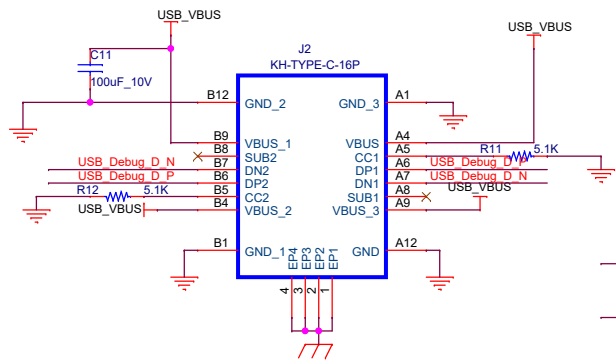
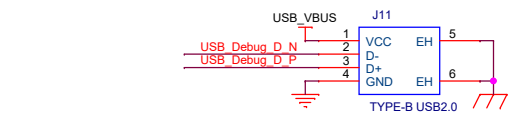

PS_UART

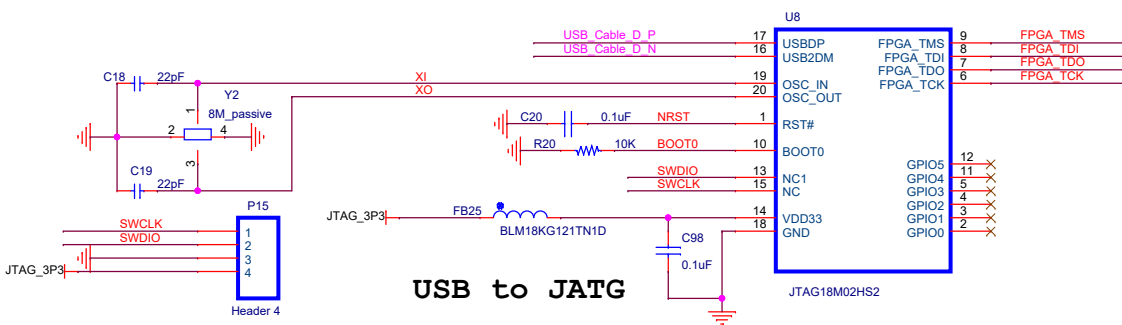
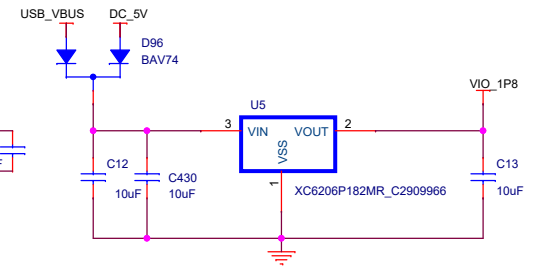
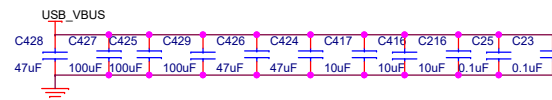
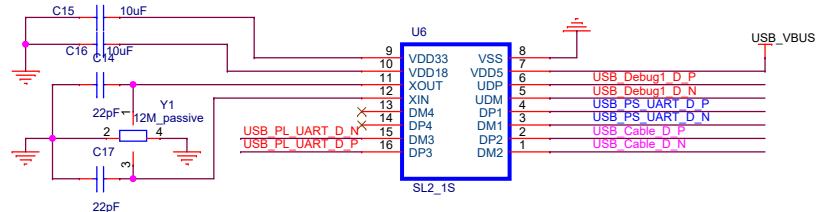

USB to JATG

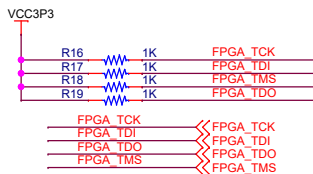
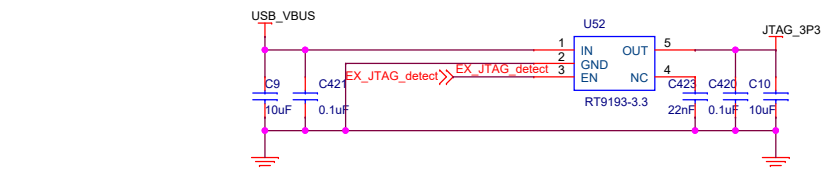

PL_UART

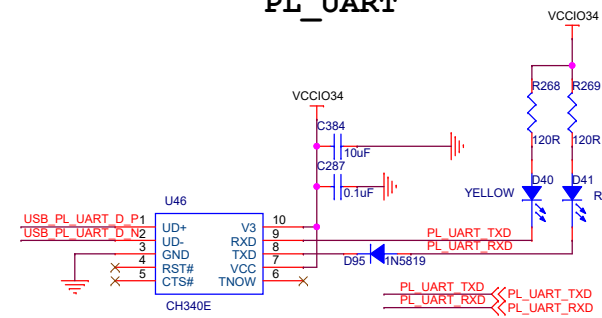

武汉芯路恒科技有限公司		
Title	AC850-CB	
Size	File	Version
A3	04_Debug_Port	25061601
Date:	Monday, September 01, 2025	Sheet 4 of 16



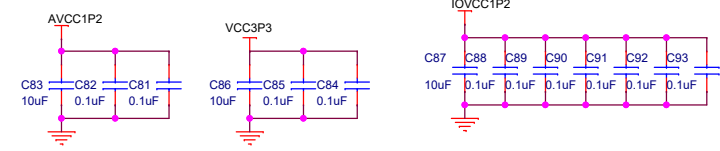
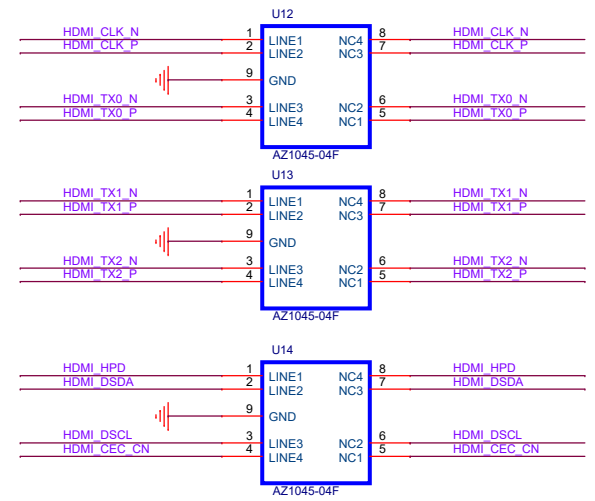
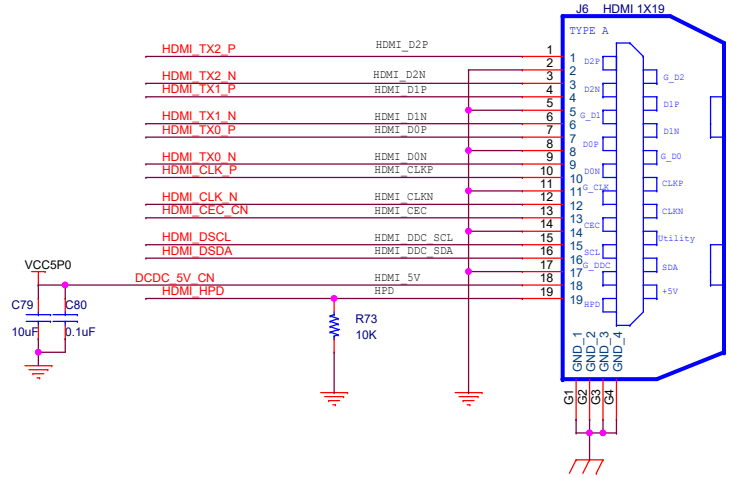
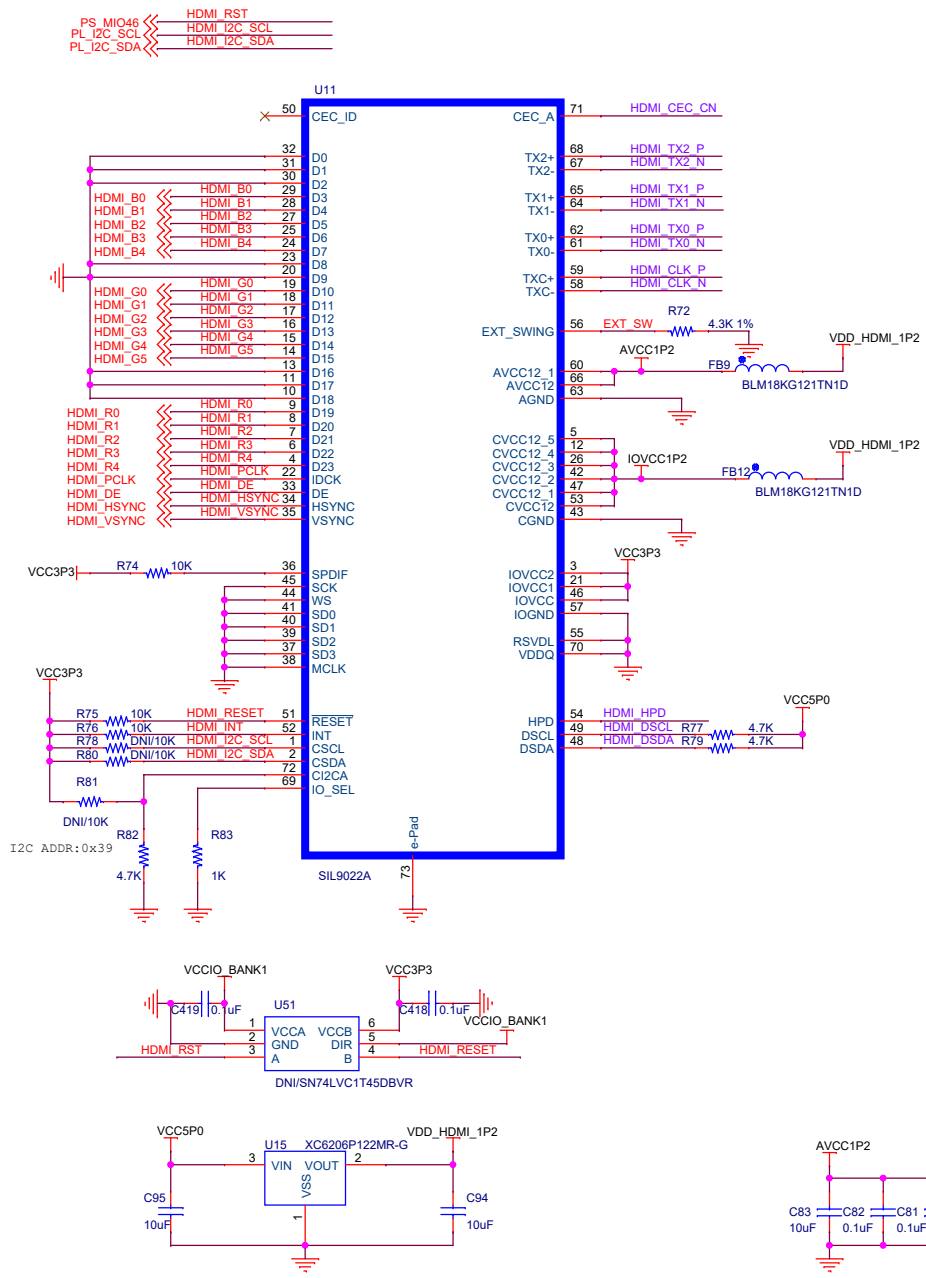

DVI_TX2_P << DVI_TX2_P
 DVI_TX2_N << DVI_TX2_N
 DVI_TX1_P << DVI_TX1_P
 DVI_TX1_N << DVI_TX1_N
 DVI_TX0_P << DVI_TX0_P
 DVI_TX0_N << DVI_TX0_N
 DVI_CLK_P << DVI_CLK_P
 DVI_CLK_N << DVI_CLK_N

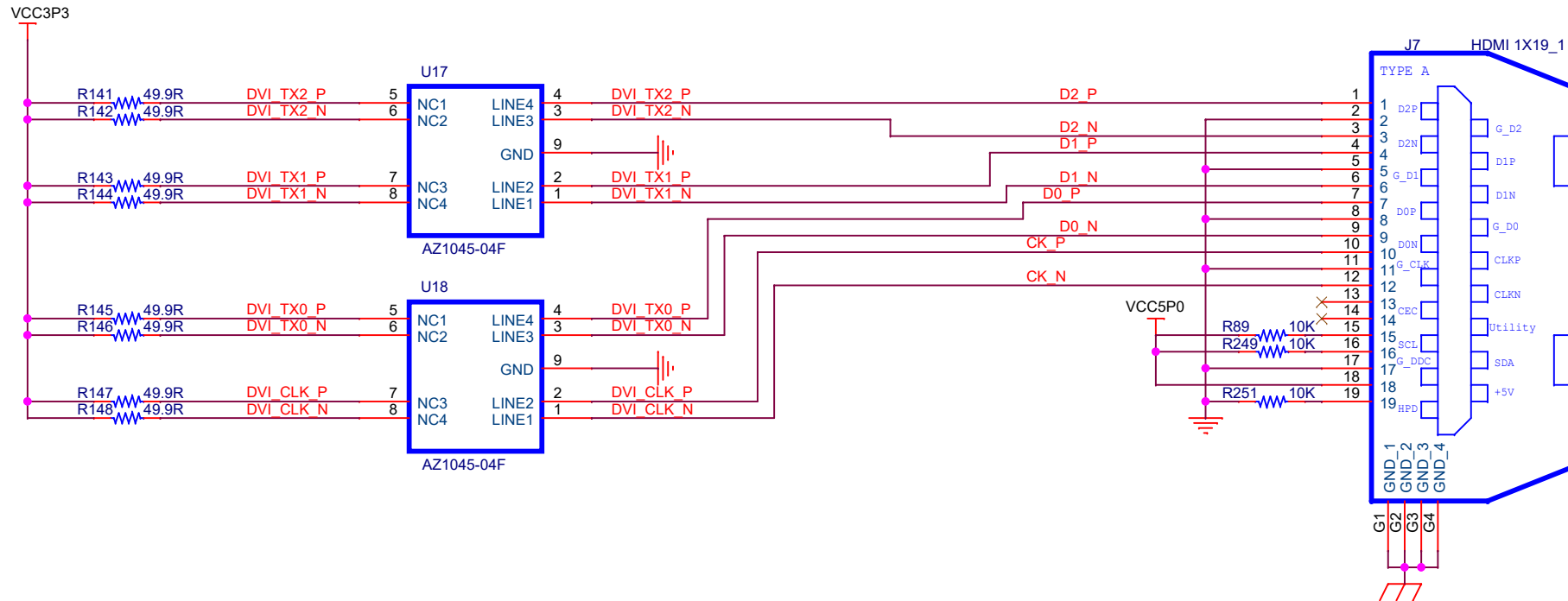

武汉芯路恒科技有限公司			
Title		AC850-CB	
Size	File	Version	
A4	06_HDMI_2	25061601	
Date:	Monday, September 01, 2023 Sheet 6 of 16		



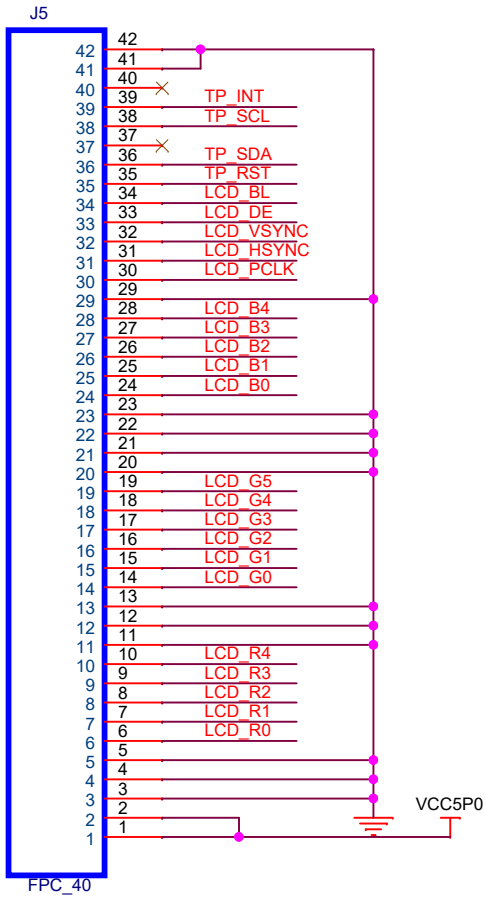

翻盖下接40P 0.5mm
FPC排线座

LCD

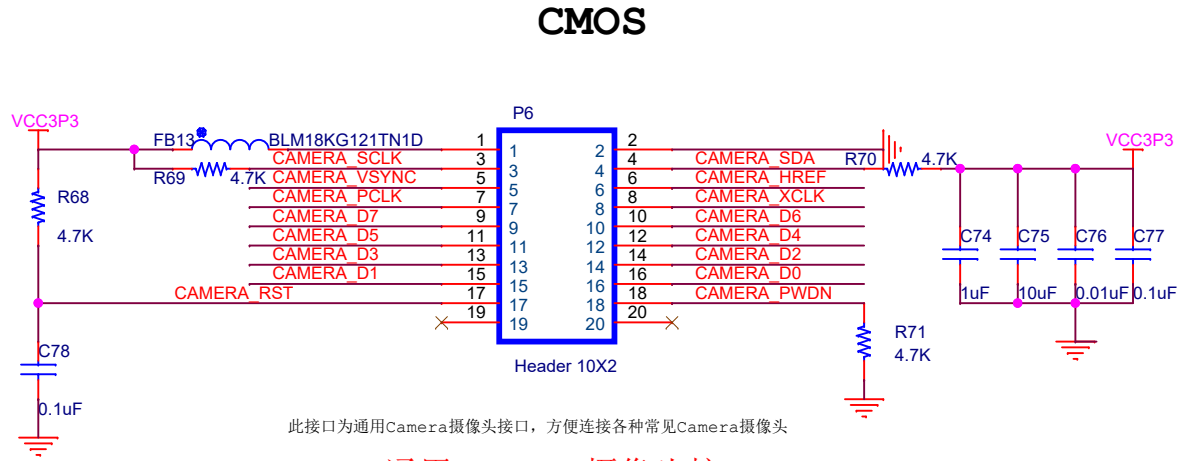

此接口为通用Camera摄像头接口，方便连接各种常见Camera摄像头

通用Camera摄像头接口

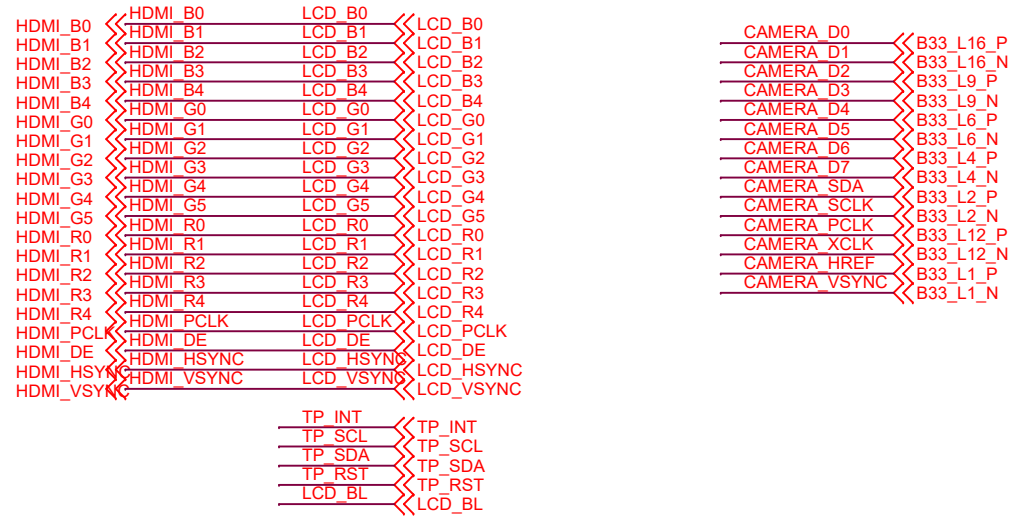

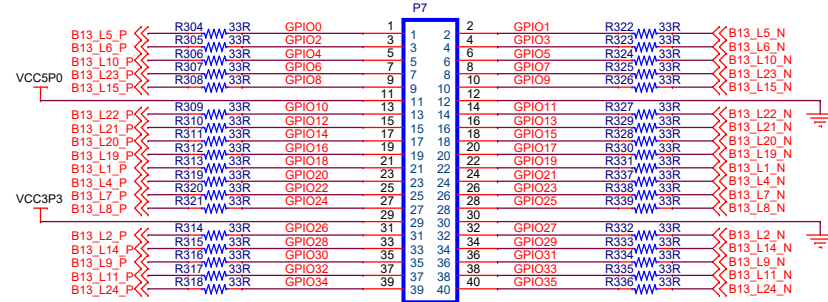

此接口为通用标准扩展接口，兼容友晶DE2开发板扩展口

兼容DE2的通用扩展接口

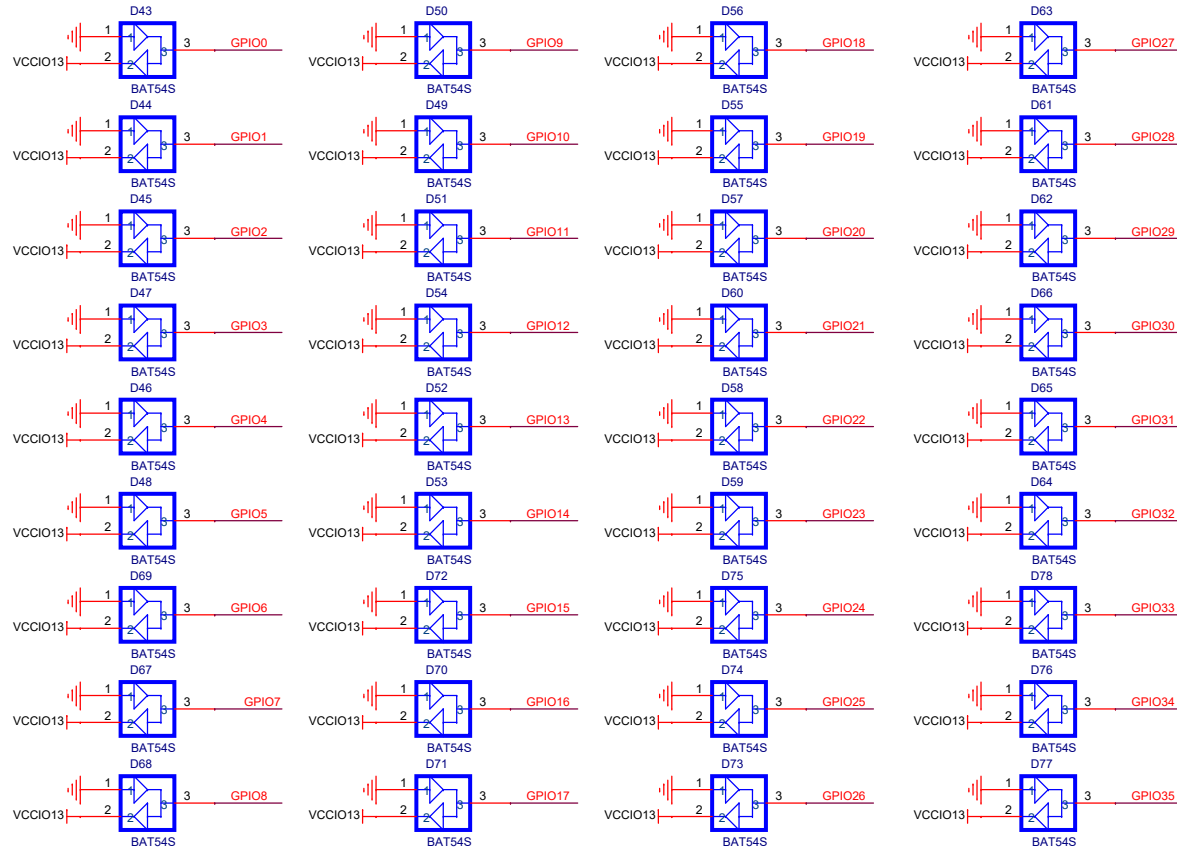

武汉芯路恒科技有限公司		
Title	AC850-CB	
Size	File	Version
A3	08_GPIO	25061601
Date:	Monday, September 01, 2025 Sheet 8 of 16	



SWITCH

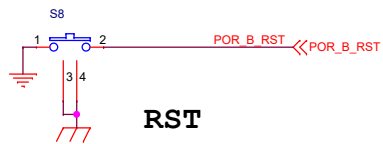
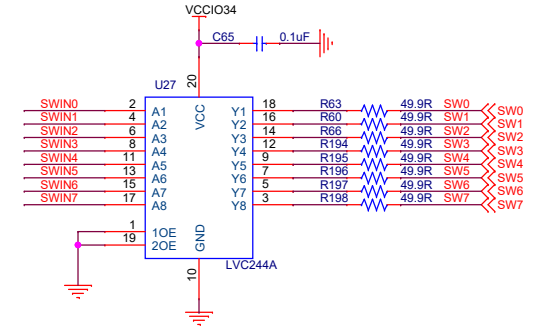
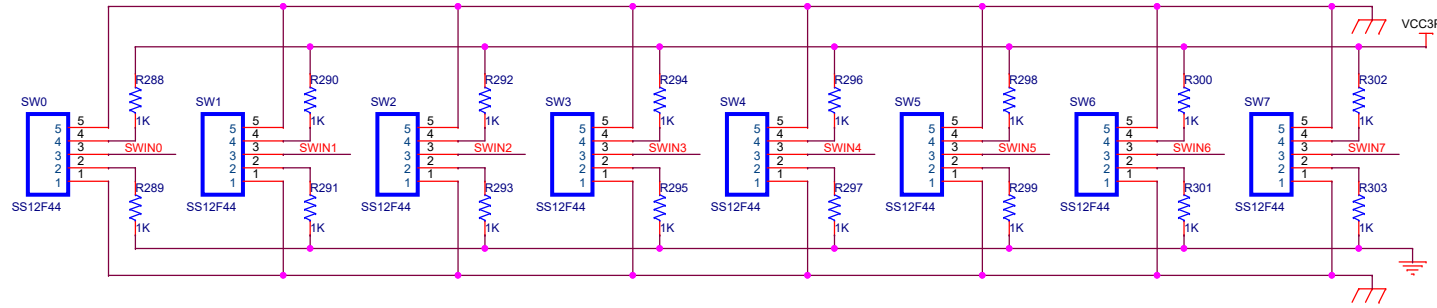

RST

PL_LED

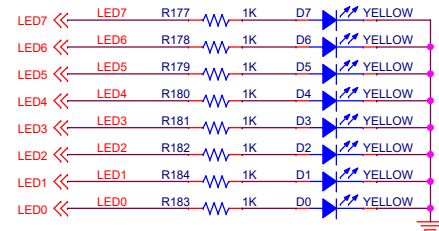

PL_KEY

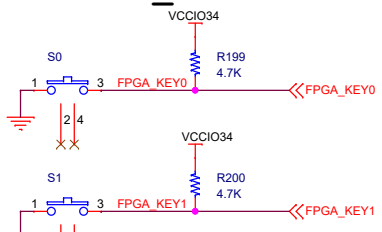

PS_KEY

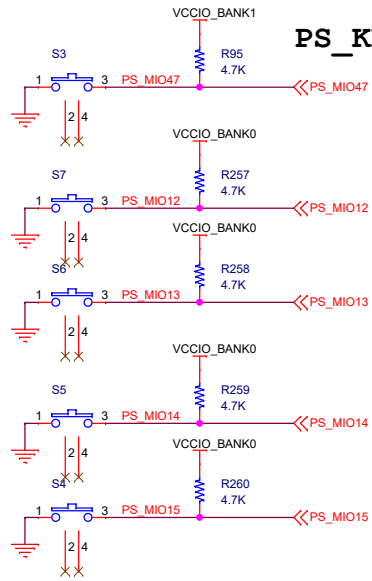

PS_LED

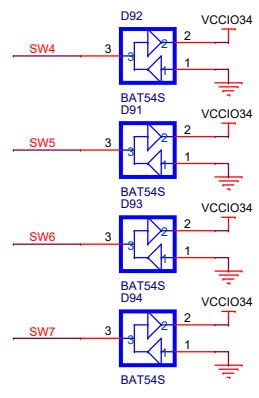
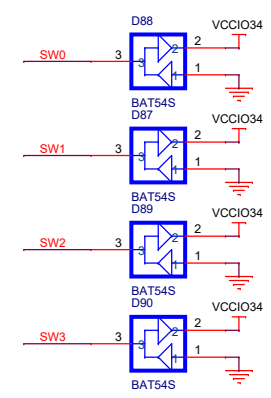
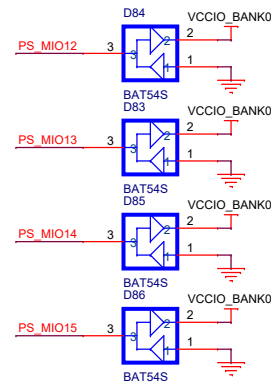
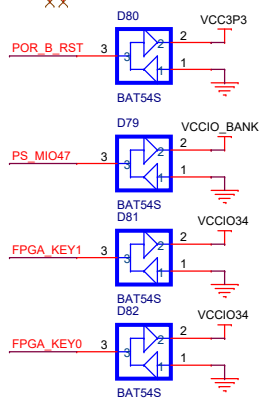
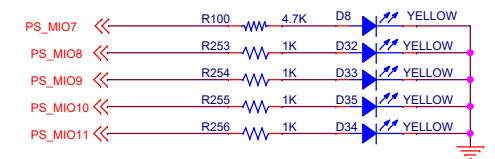

武汉芯路恒科技有限公司

Title AC850-CB		
Size A3	File 09_LED&SWITCH	Version 25061601
Date: Monday, September 01, 2025 Sheet 9 of 16		



音频编解码器

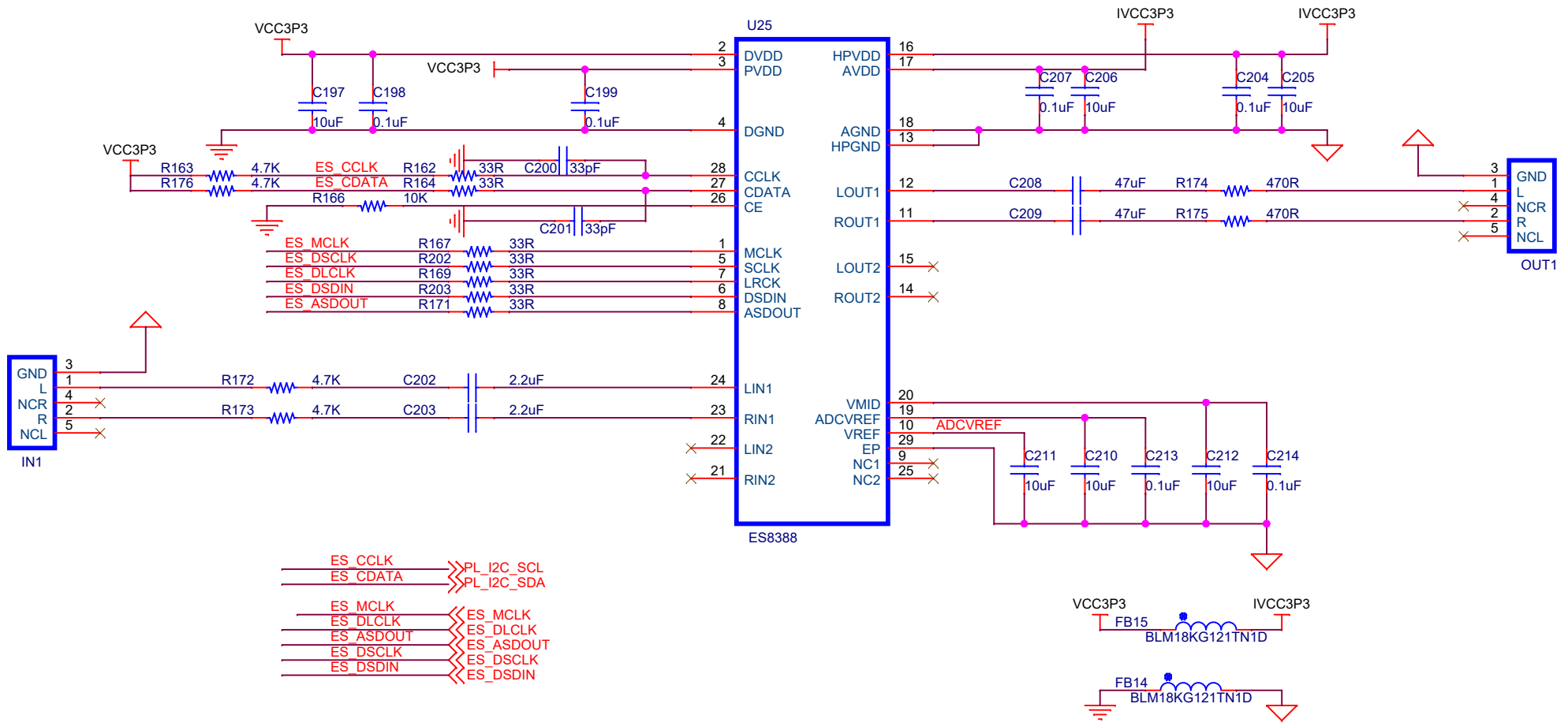

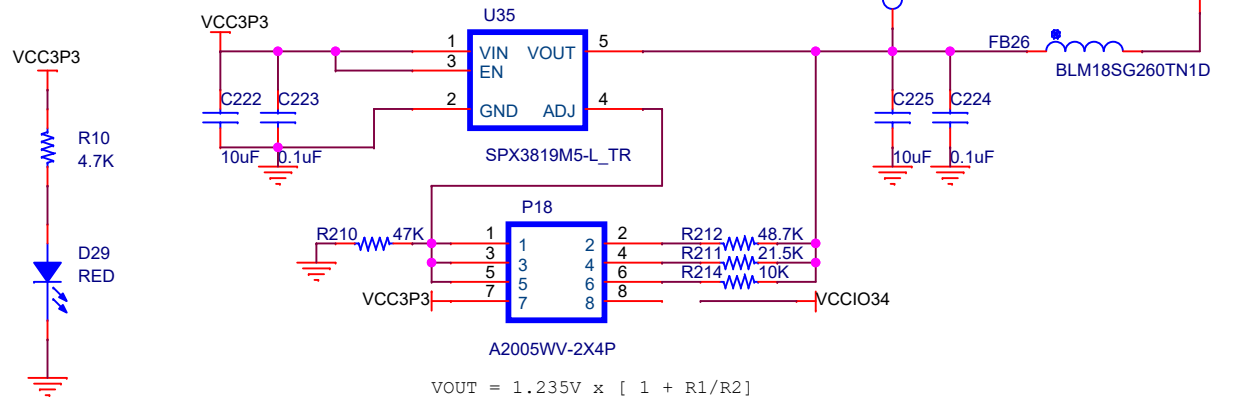
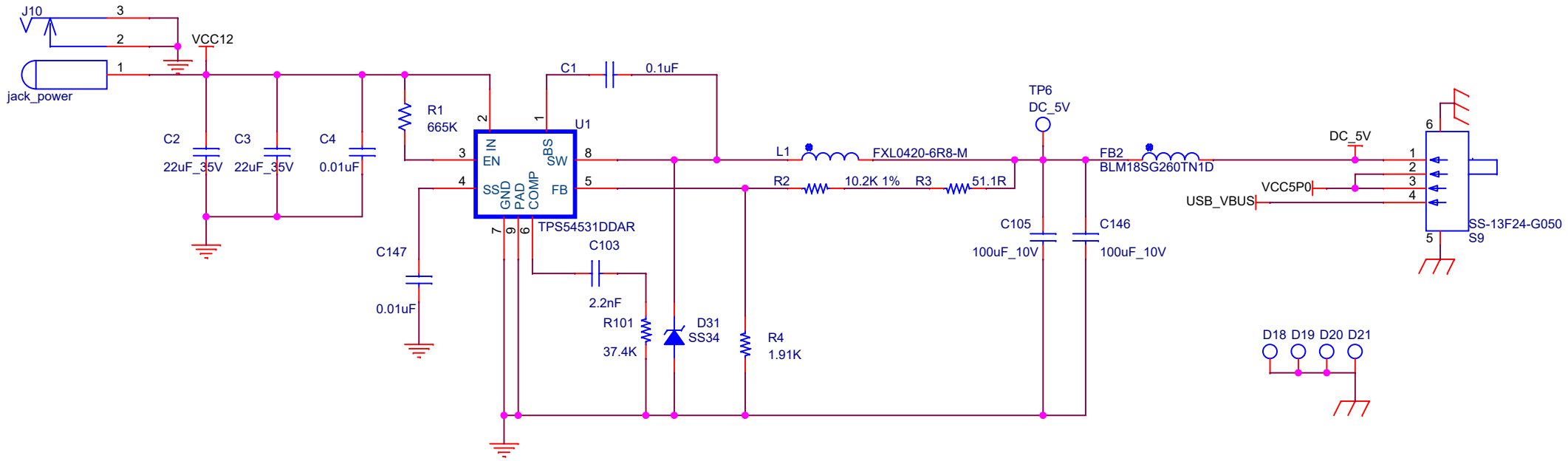

武汉芯路恒科技有限公司			
Title AC850-CB			
Size A4	File 11_Audio	Version 25061601	
Date: Monday, September 01, 2023 Sheet 11 of 16			
Date: Monday, September 01, 2023 Sheet 11 of 16			

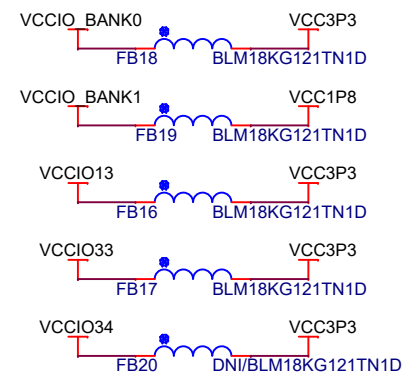

$$V_{OUT} = 1.235V \times [1 + R1/R2]$$

2.5	48.7K
1.8	21.5K
1.5	10K



武汉芯路恒科技有限公司			
Title			
AC850-CB			
Size	File	Version	
A4	12_POWER	25061601	
Date: Monday, September 01, 2023			Sheet 12 of 16

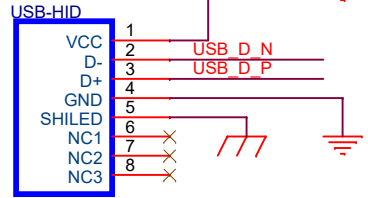

USB

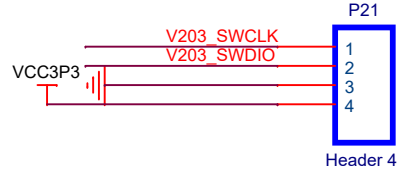

HID

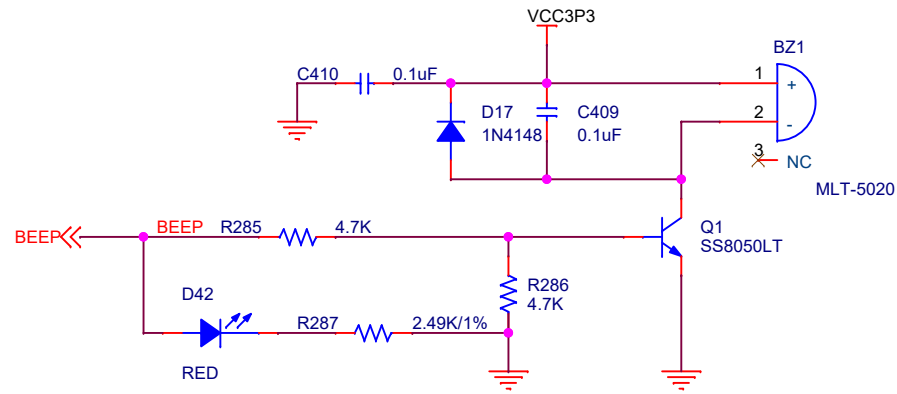
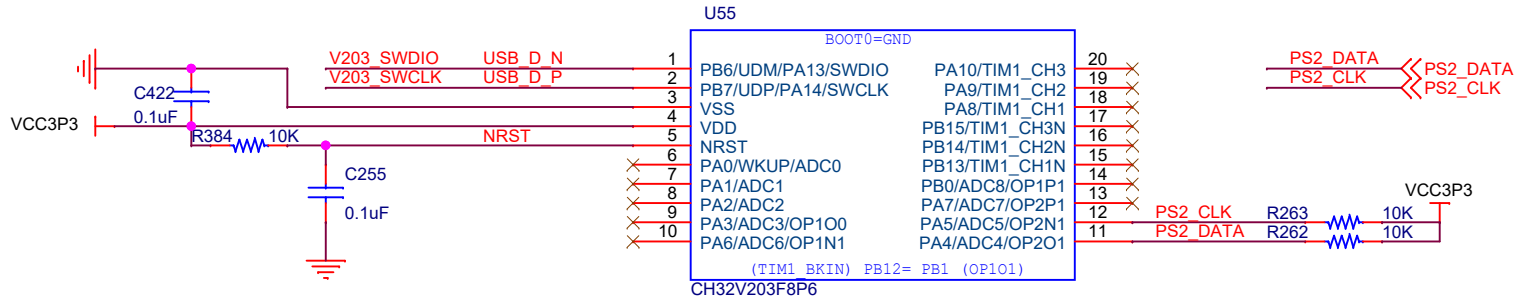

BEEP

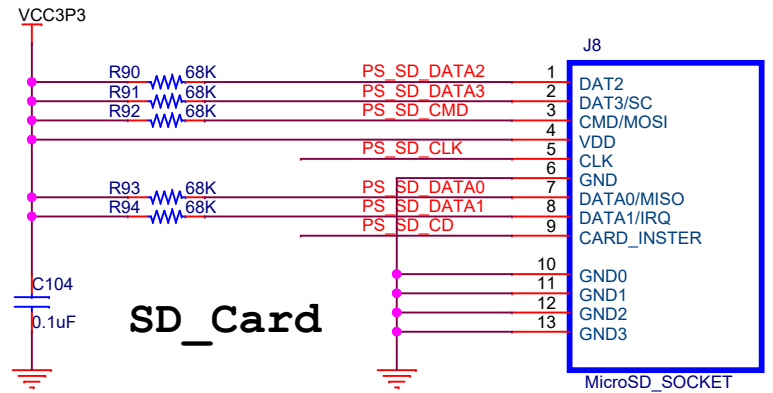

SD_Card

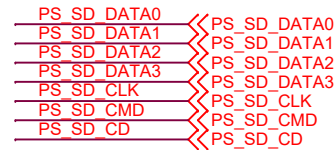

武汉芯路恒科技有限公司		
Title AC850-CB		
Size A4	File 13_HID\SD\BEEP	Version 25061601
Date: Monday, September 01, 2024 Sheet 13 of 16		



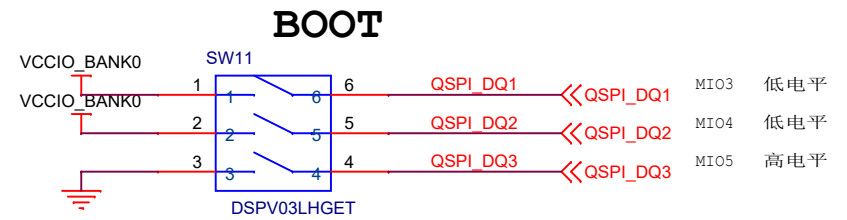
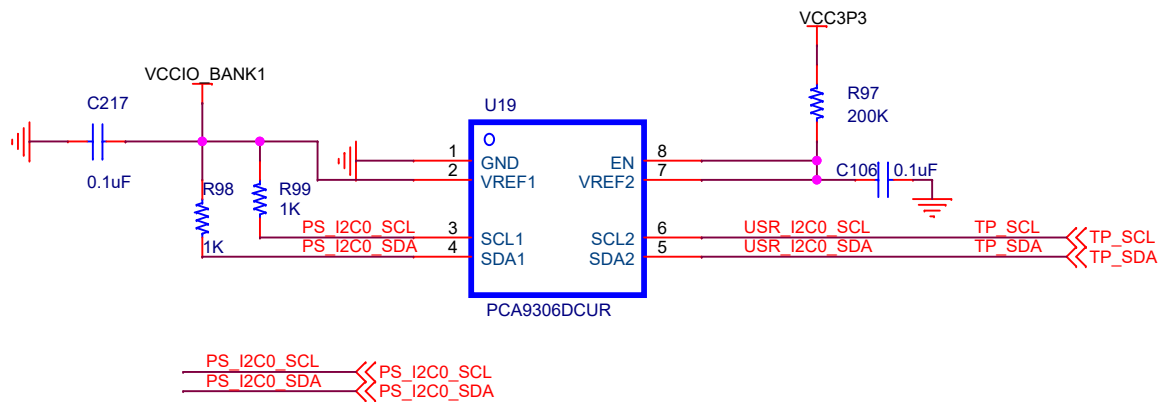

启动模式	MIO5	MIO4	MIO3	
JTAG	0	0	0	
QSPI	1	0	0	默认启动模式
SD Card	1	1	0	

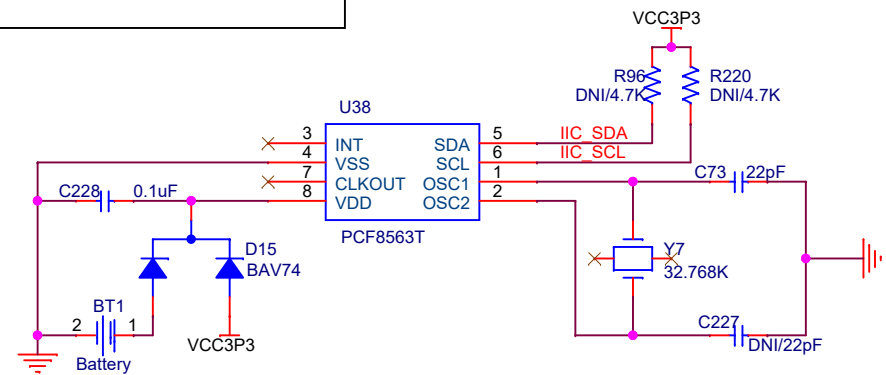
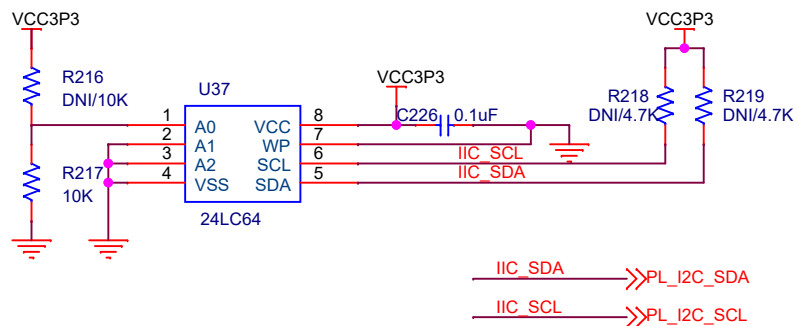
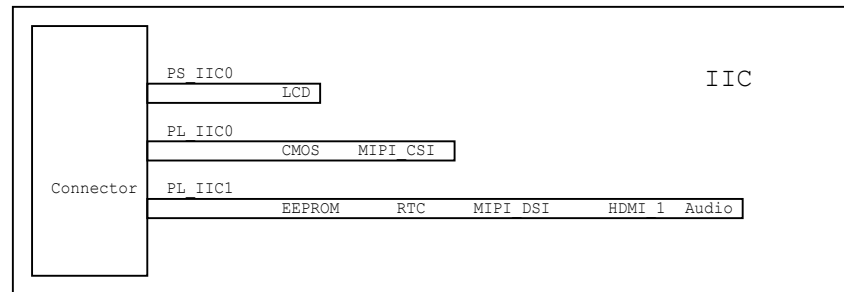

RTC

武汉芯路恒科技有限公司			
Title AC850-CB			
Size A4	File 14_I2CBOOT	Version 25061601	
Date: Monday, September 01, 2023 Sheet 14 of 16			
Date: Monday, September 01, 2023 Sheet 14 of 16			

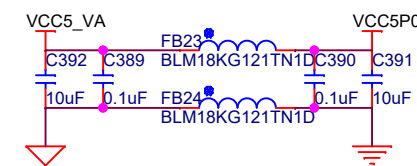
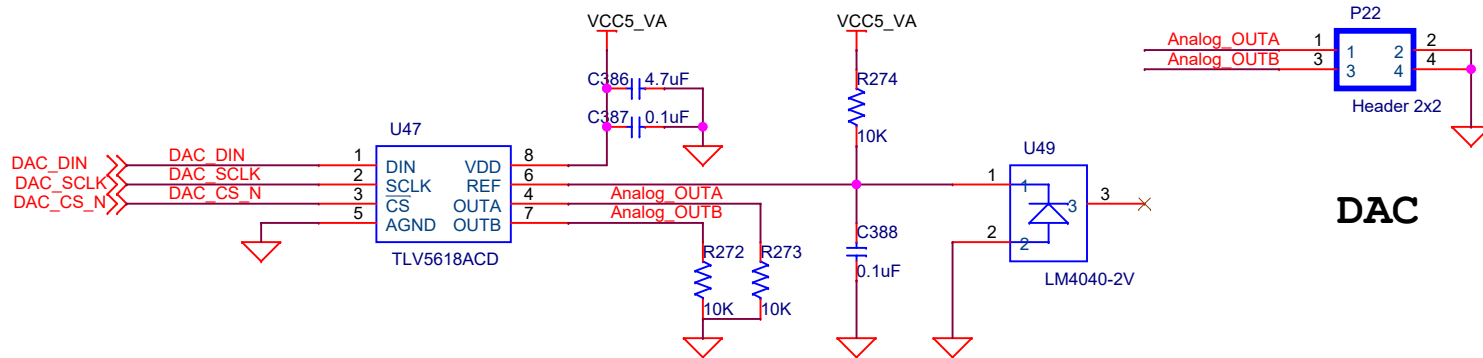

ADC

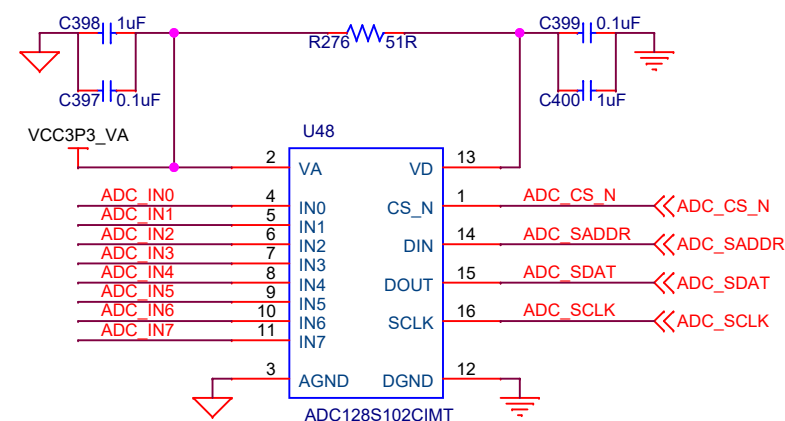
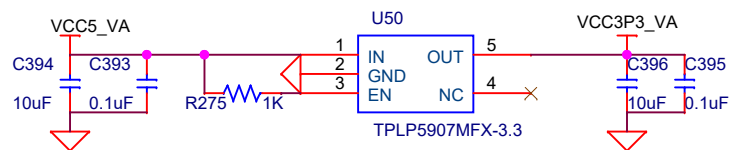
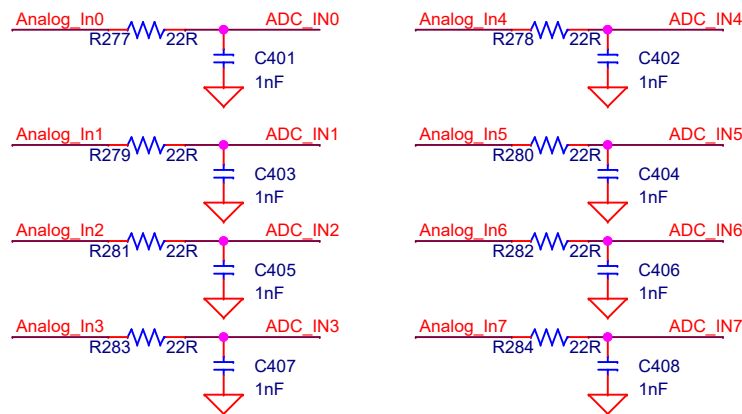
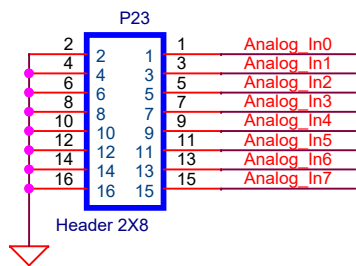

武汉芯路恒科技有限公司			
Title AC850-CB			
Size A4	File 15_ADDA	Version 25061601	
Date: Monday, September 01, 2023 Sheet 15 of 16			

